

Poignée : *Axe / Gauche*  
 PDAD : 0°

SDEC G  
 140\*140

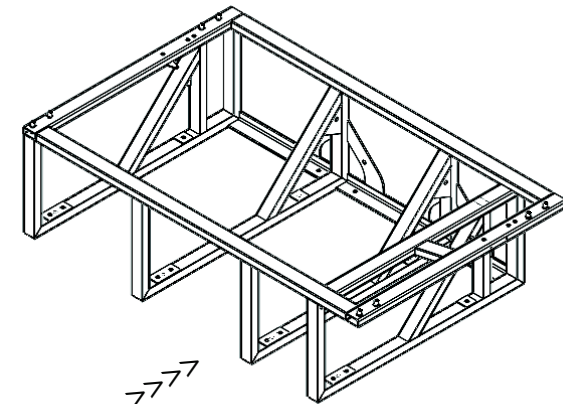

VUE FACE AVANT

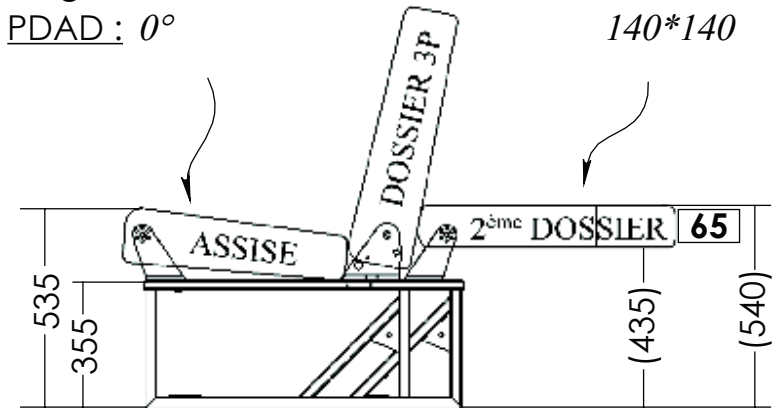

Pied 3PI -129 - Sans glissières

	N° pied : 002	Poids : 32,44 Kg	Véhicule: VWT5		
	Ref client :				
Echelle : 1:15	A4	Matière : ACIER	A	07/09/2017	AR
Traitement : Peinture	Client : KIRAVANS		IND	DATE	INIT

N° de Commande

Modèle: ALTAÏR 3PI

TYPE C - Fixation spéciale